

The RAD is a complete remote angle monitoring system capable of coordinating multiple sensors from one display.



Photo A: RAD with 2 remote Nema 4 Box/Sensors



Photo B: RAD with 2 remote N sensors



Photo C: RAS with 1 remote H4 sensor

Features

- Hand Held Display Box
- Multiple Remote Sensor Options
- $\pm 10^\circ$ and $\pm 70^\circ$ Measuring Ranges, Non-symmetrical Ranges Available
- Angle Displayed in Degrees, Percent Grade, or Inch per Foot Rise
- 0.1° or 0.01° LCD Display Resolution
- 9V Battery Power, with other power options available.
- ON/OFF Switch
- Low Battery Warning
- Relative Zero or Relative Difference
- Minimum/Maximum Angle Display
- Analog 0-5V or Digital RS232 Output Options
- Up to 4 Open-Collector Switch Outputs with Customizable Trip Angle Settings

Applications

The RAD is recommended for any application that requires remote sensing such as:

- Remote Platform Leveling
- Antenna Positioning
- Line Array/Speaker Positioning/Installation

Description

The (RAD) Remote Angle Display System provides remote angle monitoring. Designed to take angle measurements in remote locations, this battery powered digital LCD display box can be matched with various Rieker inclinometers to provide a stand-alone angle measurement system. Multiple sensors can be used interchangeably with one display box to coordinate multiple remote locations.

The RAS provides a single line LCD display (reading 1 sensor at a time), the RAD provides a dual line LCD (reading 2 sensors simultaneously).

RELATIVE ZERO and MIN/MAX functions are standard on all Remote Angle Displays. The RELATIVE ZERO allows the operator to temporarily zero the digital readout to obtain relative slope changes. The operator will always know when the device is in the REL mode by the (*) symbol that is displayed after the angle. The MIN/MAX function provides the smallest and largest angle the device has sensed since it was last reset. The optional RELATIVE DIFFERENCE function (available with the RAD only) can be programmed to give the difference between the two remote sensors.

When purchased with optional wall adapters, the following standard RDI output options become available: dual display capability; front panel green, yellow, and red LED's; RS232 outputs; up to three open collector switch outputs that can be set to switch anywhere within the external sensors measurement range. These outputs can then be used to drive external buzzers, horns, lamps, solenoids, or relays allowing for audible and visual warnings.



RAD Series

Remote Angle Display General Specifications

INPUT PARAMETERS		
Sensor Measuring Ranges	Standard	$\pm 10^\circ, \pm 30^\circ, \pm 70^\circ$
	Optional	Non-Symmetrical, can be scaled within the total sensor range.
Power Supply	Standard	9 VDC Battery
	Optional	Wall adapter (110 or 240VAC) or 8-30VDC Non-regulated
Remote Sensor	N+Nema, (Figure 3), H4 Series, (Figure 4), N Sensor (Photo B)	
DISPLAY PARAMETERS		
Output Units	Degrees	
LCD Display	Dual Line (RAD2, see Figure 1) Single Line (RAS2, see Figure 2)	
Display Resolution	Standard	0.01°
	Optional	0.1°
Min / Max Readings - Standard	Stored in Volatile Memory	
Relative Zero - Standard	Stored in Volatile Memory	
Relative Difference - Optional	Stored in Volatile Memory	
OPTIONAL FEATURES		
Display LEDs	Activated per customer request* (1 green, 1 yellow, 1 red)	
Open Collector Outputs	Up to 4 provided	
Open Collector Current	1A each	
Switch Function	Normally Open or Normally Closed	
Switch Trip Delay	0 to 16 seconds	
Switch Trip Angles	Anywhere within sensor range	
OPTIONAL RS232 OUTPUT		
RS232 Output	Decimal Output	
Baud Rate	9600	
Data Bits	8	
Parity	None	
Stop Bits	1	
DISPLAY MECHANICAL CHARACTERISTICS		
Display Housing	Die Cast Aluminum - Painted Black	
Mounting Holes	Two M4 x 0.7 or Two #8-32	
Outline Dimensions	4.53" x 3.54" x 2.21" (115 x 90 x 56mm)	
Electrical Connection	Standard	Female XLR Cord Plug Receptacle (Switchcraft PN D3F)
	Optional	Amphenol Cylindrical Connector
Weight	16 ounces, (454 grams), not including cable	
Operating Temperature	-20°C to +70°C, (-4°F to +158°F)	
Storage Temperature	-40°C to +85°C, (-40°F to +185°F)	
XLR Connecting Wire		NOTES
Pin 1	Sensor Ground	*LED trip angles can only be set within the measuring range of the device and must match the open collector switch outputs if they are chosen.
Pin 2	Sensor Signal Output	
Pin 3	Sensor Supply Voltage	

34 MOUNT PLEASANT ROAD • ASTON • PA • 19014 • USA

voice: 610-500-2000

fax: 610-500-2002

email: info@riekerinc.com

web: www.riekerinc.com



RIEKER
INCORPORATED

RAD Series

Remote Angle Display General Specifications

Figure 1: RAD2 Display Box Dimensions (inches [mm])

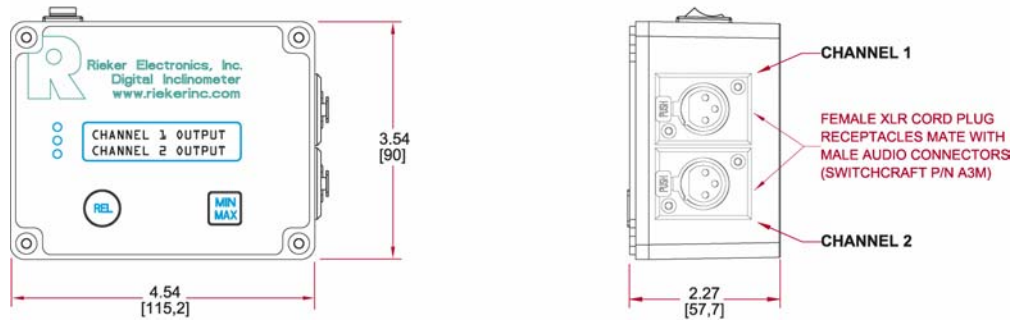
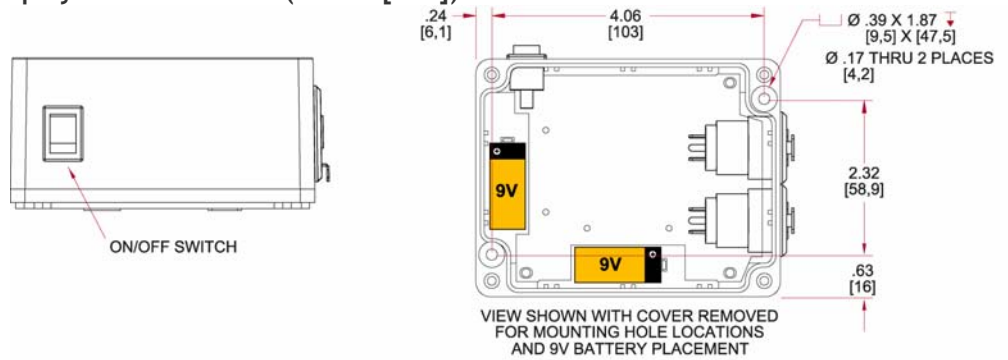
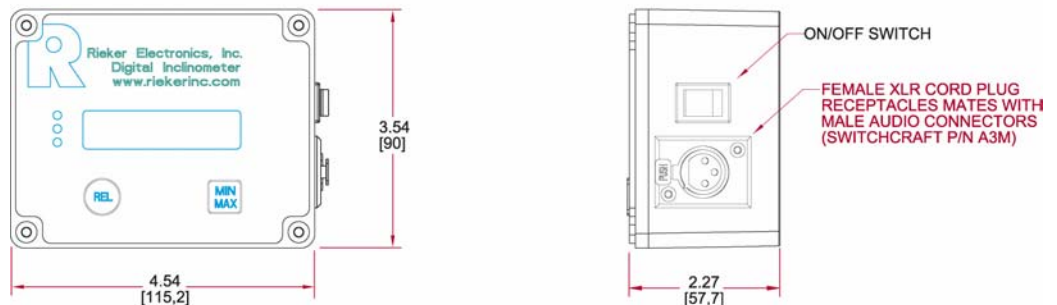
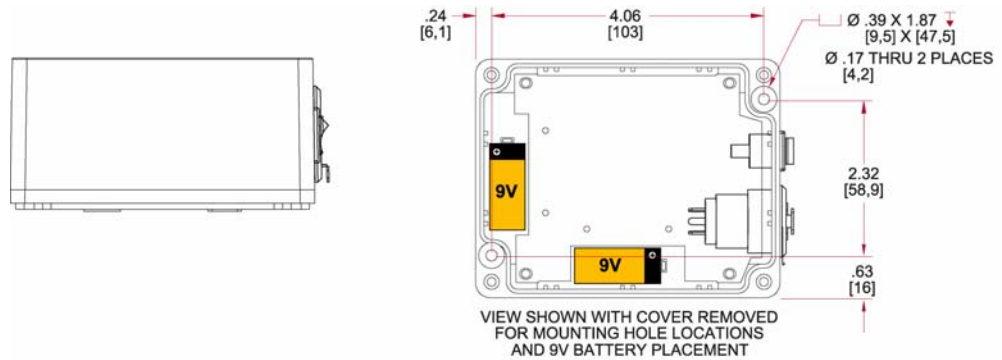

Figure 2: RAS2 Display Box Dimensions (inches [mm])



34 MOUNT PLEASANT ROAD • ASTON • PA • 19014 • USA

voice: 610-500-2000

fax: 610-500-2002

email: info@riekerinc.com

web: www.riekerinc.com



RIEKER
INCORPORATED

RAD Series

Remote Angle Display General Specifications

Figure 3: Remote Inclinator in Nema 4 Box Option Dimensions (inches [mm])



Photo C: Remote Sensor Box (Nema 4 protection) Vertical Mount

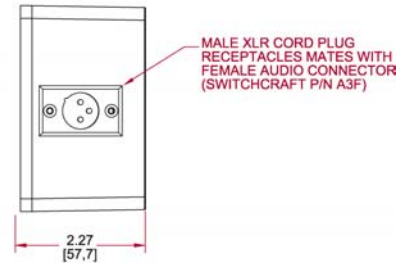
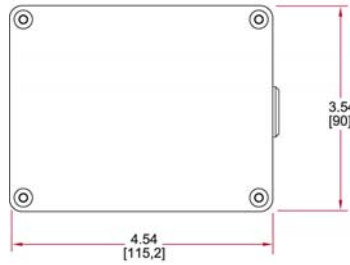
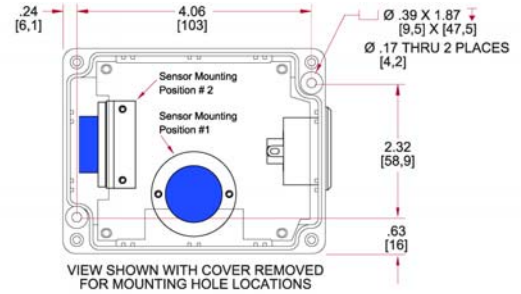

“N+Nema4 Box”; N Series sensor is mounted into Nema 4 box for extra protection, cable strain relief, and easier, more flexible mounting position. Includes XLR connector built into box. Mounts vertically or horizontally, specified at time of order. Internal mounting holes or optional mounting feet.

Figure 4: Remote Inclinator Sensor H4 Dimensions (inches [mm])



Photo D: CS9 Remote Inclinator Sensor with XLR connector.

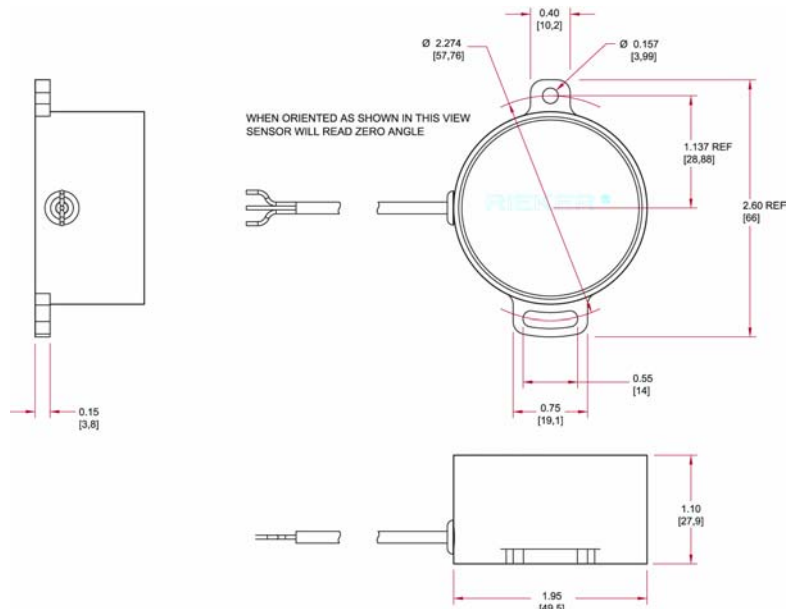

H4: Solid Zinc metal housing, small footprint, sturdy and extra rugged for a more permanent mounting. Includes XLR connector. Mounts vertically.