



RIEKER
INCORPORATED

SB1i (4-20mA)

Single Axis Inclinometer Sensor Package

Page 1 of 4

The SB1i is a rugged, environmentally sealed sensor package with an integrated inclinometer & signal amplifier for a 2-wire Analog Current 4...20mA output.



Features

- *Specially designed Aluminium housing for extra stable sensor platform with sea water resistant coated finish*
- *IP65 to IP67 Environmental Protection*
- *4...20mA amplifier for 2- wire connection*
- *Temperature compensation beyond the sensors own compensation data*
- *No extra power required*
- *Angle measuring range can be scaled to customer requirements*
- *Sensor and amplifier are galvanically separated from the housing*
- *Extensive EMC protection*
- *Highly stable sensor supply voltage*
- *Dynamic parameters are programmable*
- *Current-loop with maximum current limitation*
- *High overload resistance*
- *Reverse polarity protected*
- *Low-pass signal filter with optional setting of maximum frequency for suppression of interference frequencies*

Description

The SB1i sensor box is packaged in a solid and compact pressure-cast Aluminum housing with an integrated sensor for single axis inclination or acceleration measurements.

Within the box are 2 sections: An amplifier with a 4...20mA output signal - allowing a 2-wire system; and a separate highly stable power supply for the sensor. The amplifier contains a low-pass filter for upper frequency limitation, with noise suppression filtering and a diode bridge for the unipolar current-loop operation. Both sensor and amplifier are galvanically isolated from the housing - further reducing susceptibility to outside noise. Specific response time constants and maximum current output limitations are additional options.

For a higher degree of accuracy, an NG-type sensor can be integrated into the SB1i box, which considerably reduces temperature drift over the entire temperature range. Add a strong metal PG cable fixing combined with the 2-wire current-loop output the SB1i provides a high-quality system for use under many types of harsh working conditions.

Applications

The SB1i is used where inclination or acceleration measurements need to be combined with a 4...20mA current-loop output: especially where noise and/or distance to source are a concern. Typically used in building and bridge construction, mining, radar alignment systems, pitch and roll, agricultural equipment, and all types of process machinery.

34 MOUNT PLEASANT ROAD • ASTON • PA • 19014 • USA

voice: 610-500-2000

fax: 610-500-2002

email: info@riekerinc.com

web: www.riekerinc.com



RIEKER
INCORPORATED

SB1i (4-20mA)

Single Axis Inclinometer Sensor Package

TECHNICAL DATA	
Termination/Cable Diameter	max.: 3 x 1.5 mm ² / Ø 5 ... Ø 7 mm
Cable Fixing	PG7 (Metal with integrated stress relief)
Measuring Ranges	In accordance with the actual sensor
Protection Degree	IP65 (with RTV fill IP67)
Mounting	Any direction
Inclinometer Measuring Plane	N Series: 3 directions of mounting
	NG Series: Parallel to the base of housing
Accelerometer Measuring Directions	B, BD Series: Place in X, Y, Z co-ordinates to the housing
Supply voltage to the box	+8 ... +30 Volt
Minimum loop current	3mA
Maximum loop current	Approx. 24mA
Output current loop signal	4...20mA (12mA as zero point)
Adjustable parameters via potentiometers	Signal-zero (12mA), Span
Max. Load impedance	500 Ohm (at 24 Volt loop supply)
Operating temperature	-40 ... +85°C
OPTIONS	
Special measuring ranges, test report, silicone filled housing, custom wiring	
<p>The SB1i Sensor Box is extremely versatile, allowing various configurations with other Rieker sensors. If you have an application that requires alternative specifications, one of our engineers will be happy to discuss how to customize the box for your inclination or acceleration needs.</p>	

FIGURE 1: Dimensions ([mm]) and Mounting Position
(Shown with NG-type inclinometer sensor)

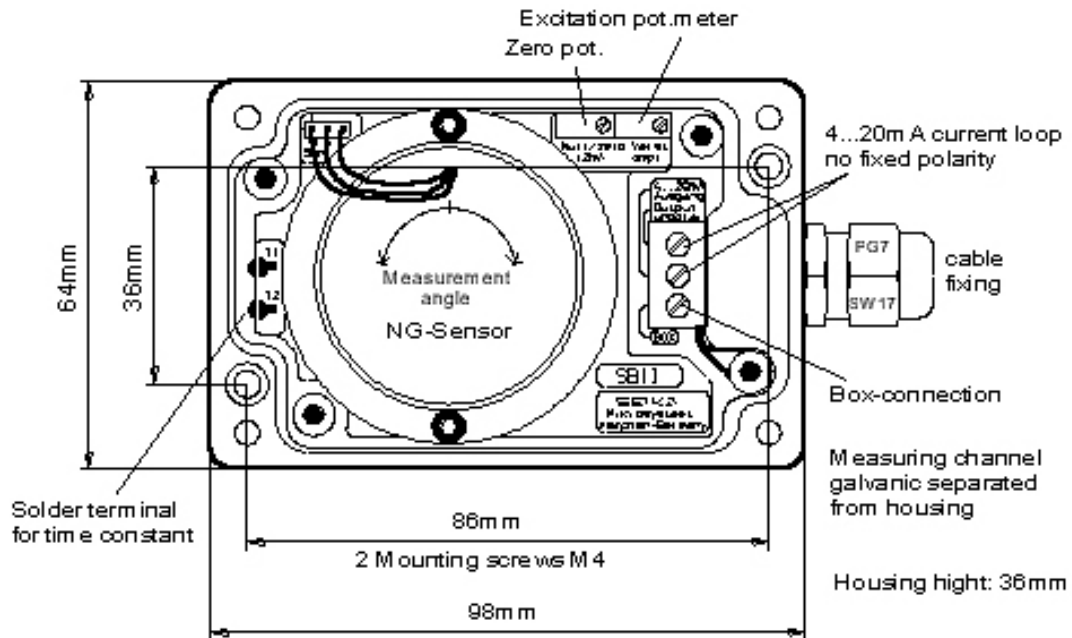

34 MOUNT PLEASANT ROAD • ASTON • PA • 19014 • USA

voice: 610-500-2000

fax: 610-500-2002

email: info@riekerinc.com

web: www.riekerinc.com



RIEKER
INCORPORATED

SB1i (4-20mA)

Single Axis Inclinator Sensor Package

FIGURE 2: Dimensions ([mm]) and Mounting Position
(Shown with N- or NB-type inclinometer sensor or B- or BD-type Accelerometer)

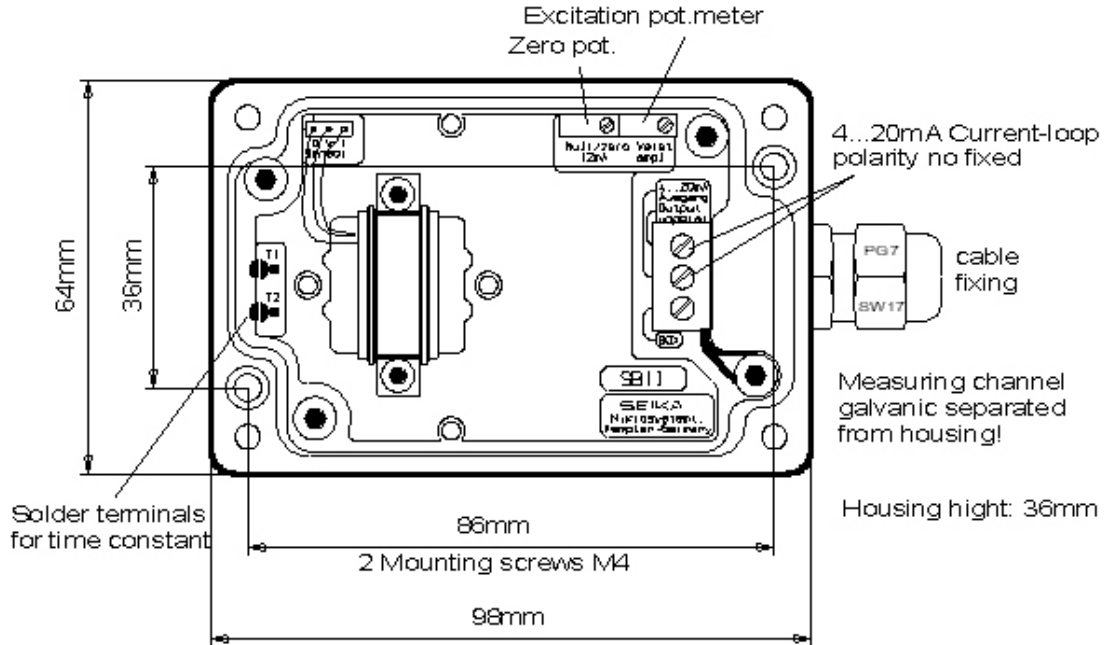
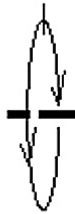

FIGURE 3: Measuring Level and Rotation Directions

Sensor Type: N, NB, B, BD, BDK



N-type Sensor

Angle zero can be (\pm) rotated in both directions.

Cable output from the sensor box can be from the right (as shown), from the left, or the top. The NG-types have similar measuring directions.

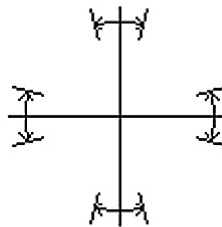

NB-type Sensor

Zero point mountable in 90° steps.

Rotation in both directions possible.

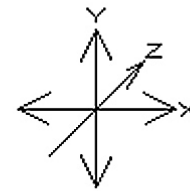

B, BD, BDK-type Sensors

Acceleration measurement is possible in X, Y, and Z direction through corresponding mounting position.

\pm measuring possible in X and Y directions.

34 MOUNT PLEASANT ROAD • ASTON • PA • 19014 • USA

voice: 610-500-2000

fax: 610-500-2002

email: info@riekerinc.com

web: www.riekerinc.com



RIEKER
INCORPORATED

SB1i (4-20mA)

Single Axis Inclinomometer Sensor Package

FIGURE 4: Block Diagram and Wiring Connections

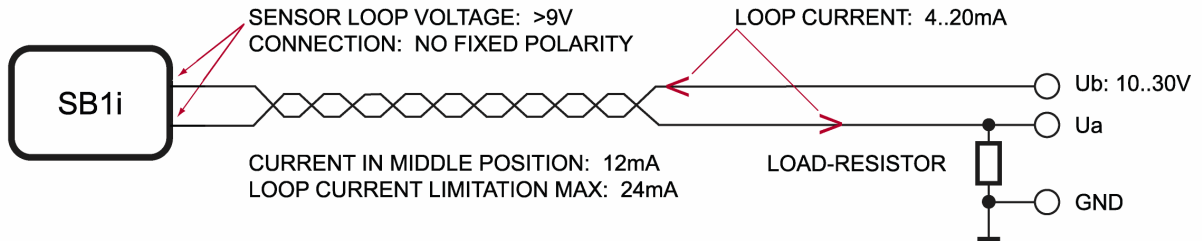
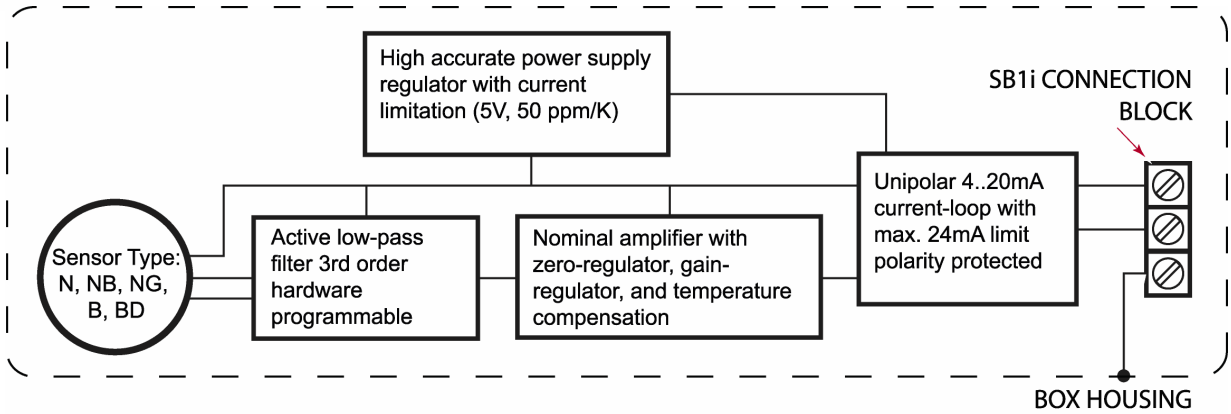

MINIMUM LOOP CURRENT = CURRENT SUPPLY SENSOR + ELECTRONICS < 4mA

$U_b \text{ MIN} = 9V + \text{VOLTAGE DROP IN CABLE} + \text{VOLTAGE DROP OVER LOAD-RESISTOR TO } 20\text{mA}$

$U_b \text{ MIN} = 9V + (20\text{mA} \times R [\text{CABLE}]) + (20\text{mA} \times R [\text{LOAD-RESISTOR}])$

e.g. 1) (100M WIRE 2 x 0, 14MM:) 0.6V + (RESISTOR 100 Ohm:) 2V + 9V = $U_b \text{ MIN} = 11.6V$

e.g. 2) (2KM CABLE 2 x 0, 5MM:) 3.2V + (RESISTOR 500 Ohm:) 10V + 9V = $U_b \text{ MIN} = 22.2V$

NOTES: Since the supply voltage for the SB1i is obtained from the current-loop and requires a max. 3mA, an input voltage of 9 Volts/min. must be present at the connection block. This is also required in order to guarantee correct operation when the highest loop current of approximately 24mA is used.